

R.L. HAYDEN FURNITURE CO.

1/220 Scale Laser Kit



THANK YOU . . .

for purchasing this kit. I honestly hope you enjoy building it. I'm a z-scaler at heart and I'm happy to provide fellow z-scalers with a wider variety of structures to populate their layouts, modules, and dioramas. This kit is a great medium-size line-side industry, it's modeled after a similar structure on Dave Clune's On3 layout featured in **The 2008 Narrow Gauge Annual**.

TOOLS

Here is a list of tools that will greatly aid assembly:

- **Knife:** A hobby knife with a sharp #11 blade - such as the classic Exacto - is great for removing parts from the carrier sheet.
- **Tweezers:** Remember this is Z-scale. There are many small parts to deal with and using a pair of tweezers can be a great help.
- **Paint:** Everybody has their personal favorite. I use Polly S acrylic but almost anything will work. Brush, air-brush, even spray paint works in a pinch. The way the parts break down makes it easy to paint trim and windows separately from the walls before assembly
- **Stains:** You can always use the time tested India ink and alcohol wash to stain walls. Just remember, it will probably warp the plywood walls. You can always place them between two sheets of glass while they dry to ensure they remain straight and true.
- **Glue:** Many parts are peel-and-stick but some glue is required. I personally like to use AC (super glue). Others would rather work with wood glue like Elmers. Either will work just fine so pick your poison.
- **Glue Applicator:** A small piece of wire, a T-pin, a toothpick. All make great glue applicators. I put a big drop of glue on a scrap of cardboard and then use a T-pin to pick a little up on the tip.

PAINTING

As mentioned before, the kit breaks down into neat sub-assemblies for painting. I usually build up the windows (leaving the clear plastic "glass" off) and the doors and then paint them. I'll build up the roof sub-assembly and paint it the same color as the doors and windows. Then I'll build the structure shell and paint it a contrasting color. I continue to put together the sub-assemblies based on what areas I want to be a solid color. This makes for a really crisp line between two painted sub-assemblies (such as the windows and the walls). Some people, on the other hand, prefer to paint the pieces while they are still attached to the carrier sheets. Experiment and find out what works best for you.

Either acrylic or enamel based paints work fine. As mentioned before I prefer Polly S Acrylics. Remember if you are using water based paints, do so sparingly. If you use too much you can cause warping of the walls (or other broad, flat parts). Recently I heard someone mention a remedy to warping walls. Secure the walls to sheet of glass using double-sided tape and then paint them. Wait until the paint is dry before removal and you should have nice, straight, painted wall.

ADDITIONAL HELP

Hopefully building this kit will be an enjoyable experience. But if you encounter any problems please let me know. Email me at info@fannocreekdesigns.com.

PARTS LIST

1/32" plywood parts (a)

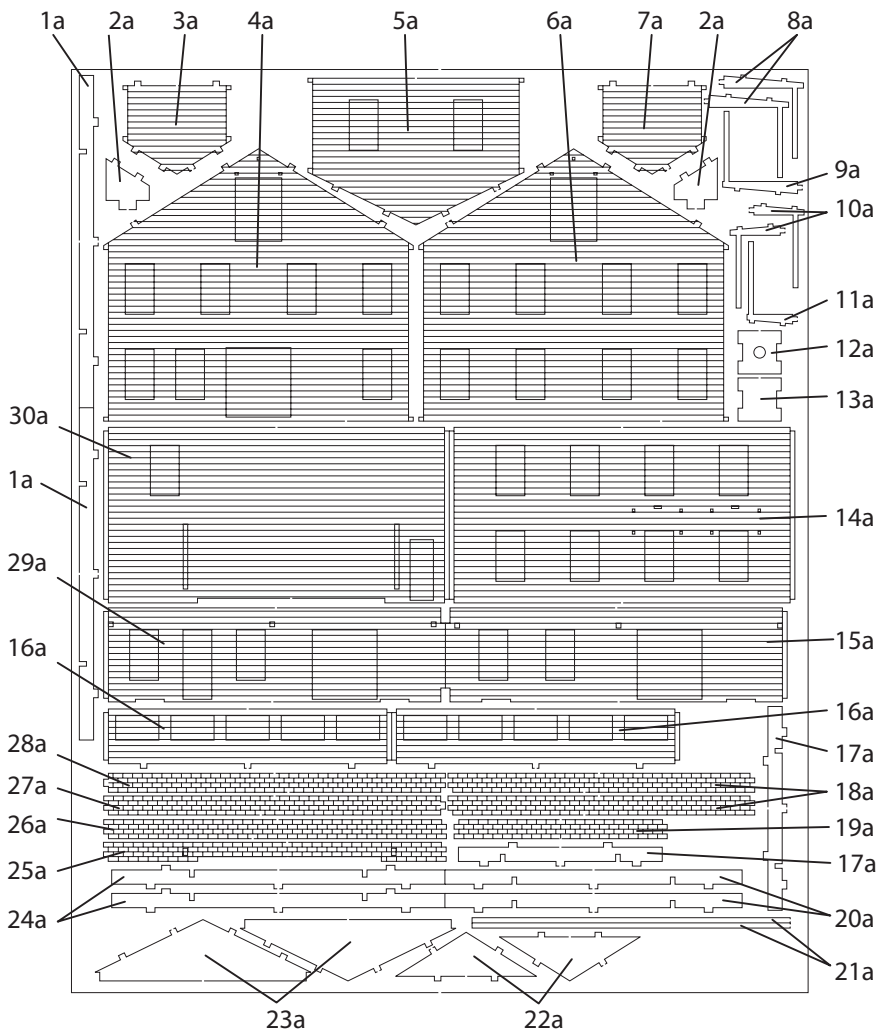

1/32" plywood parts (b)

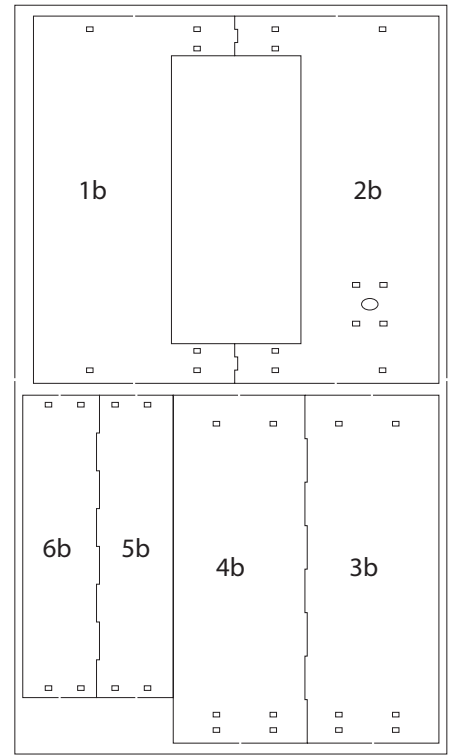

1/32" plywood parts (c)

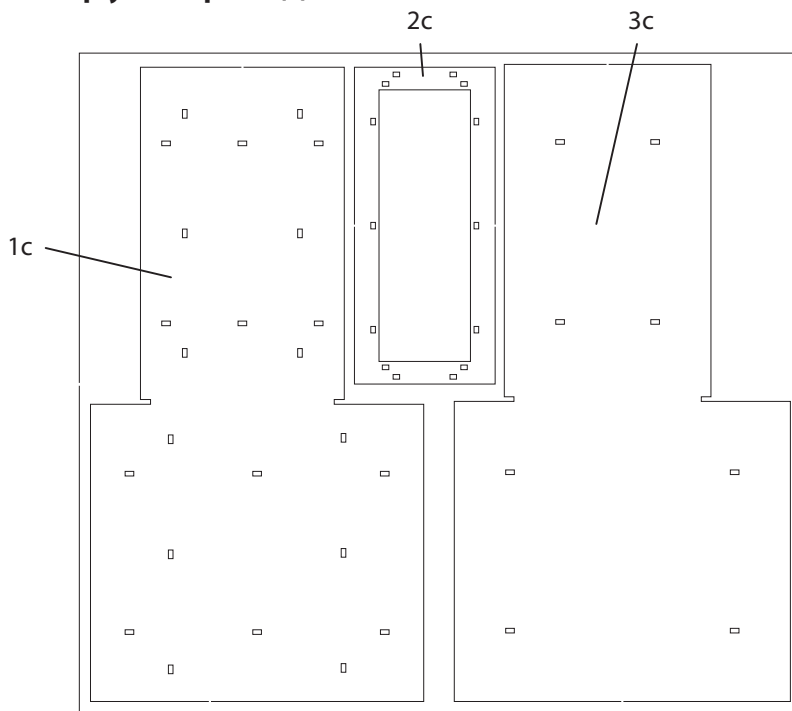

.010" paper parts (d)

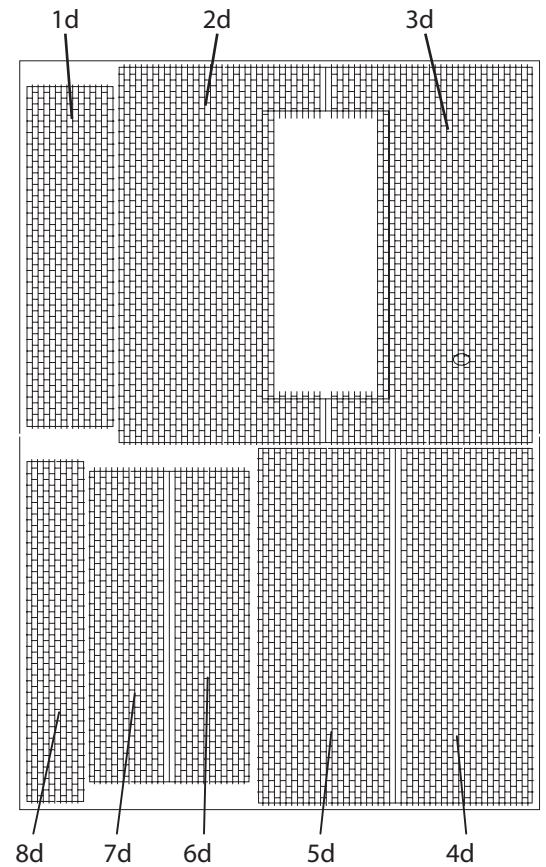

PARTS LIST (continued)

1/64" plywood parts (e)

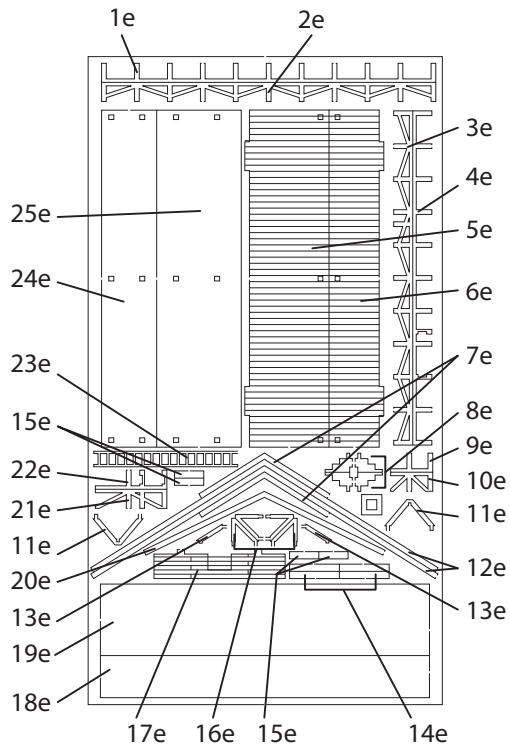

Lazerboard parts with peel-and-stick adhesive (f)

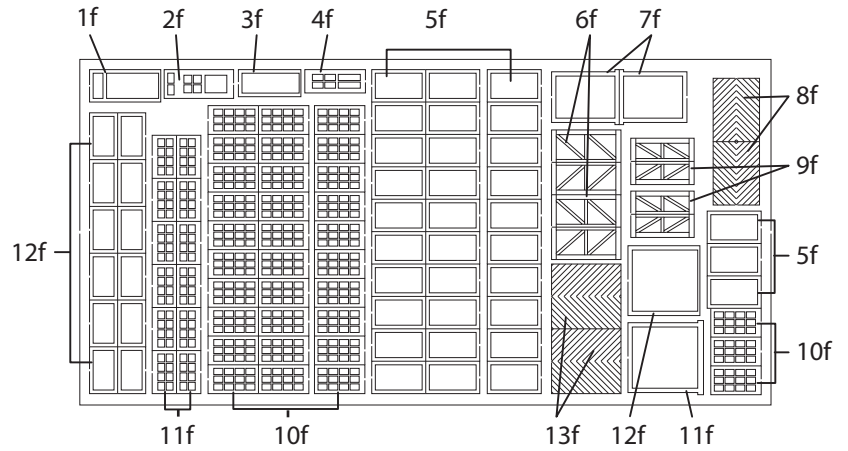

Lazerboard parts (g)

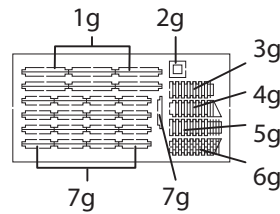

.010" clear plastic parts (h)

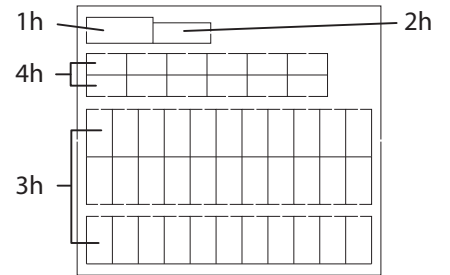

<p>1(x10)</p>	<p>2(x10)</p>	<p>3</p>	<p>4</p>
<p>5</p>	<p>6</p>	<p>7(x2)</p>	

8

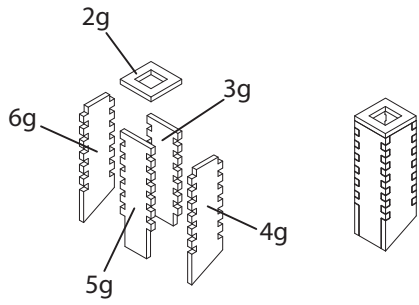

9

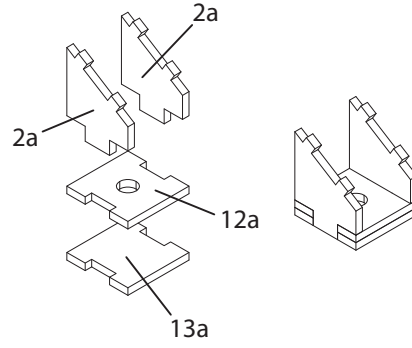

10

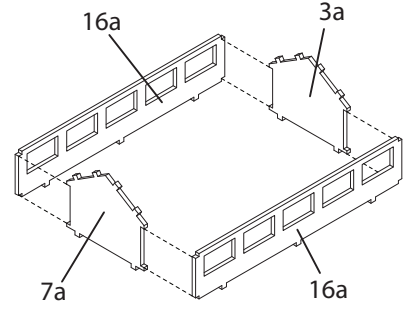

11

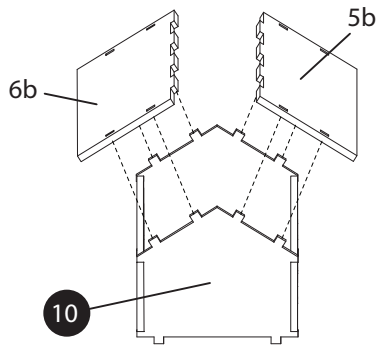

12

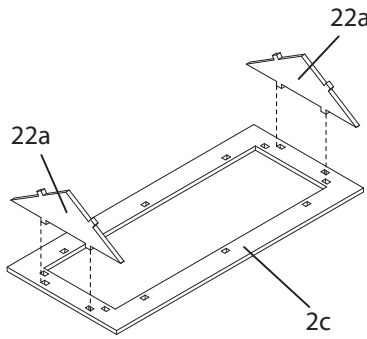

13

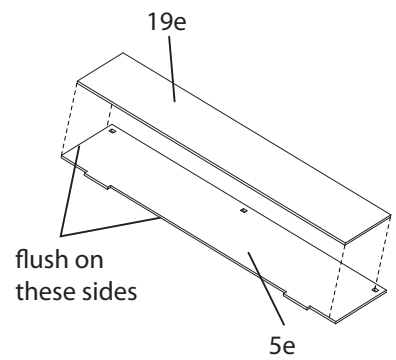

14

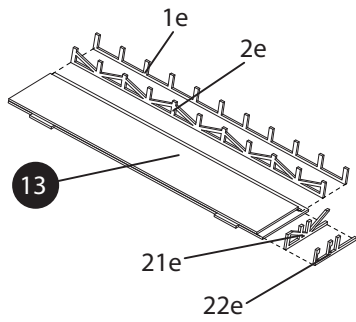

15

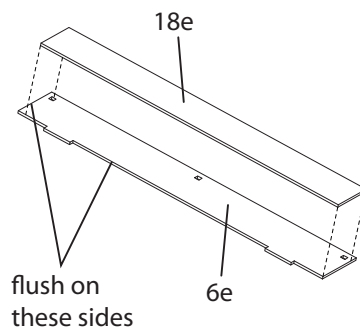

16

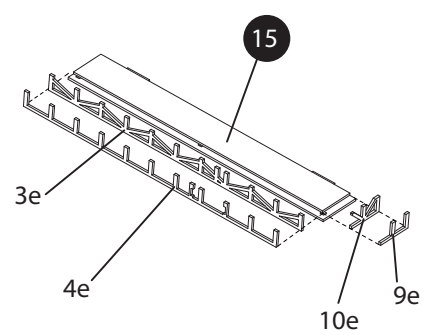

17

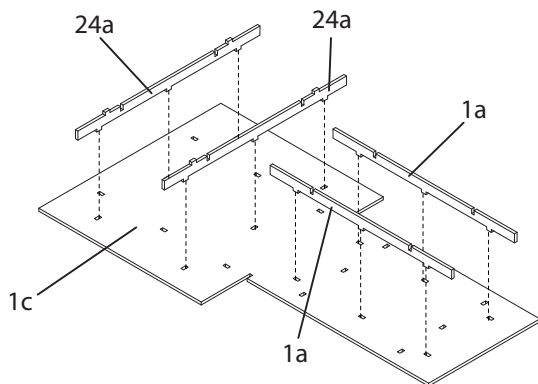

18

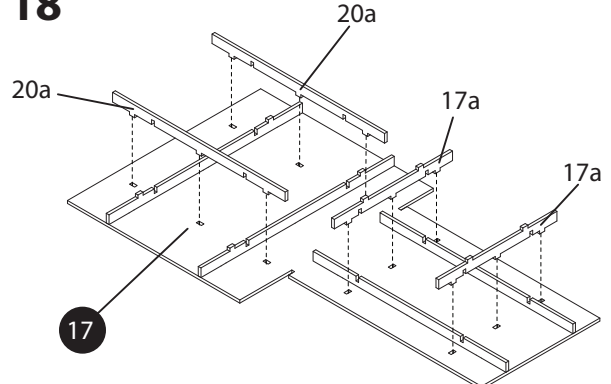

19

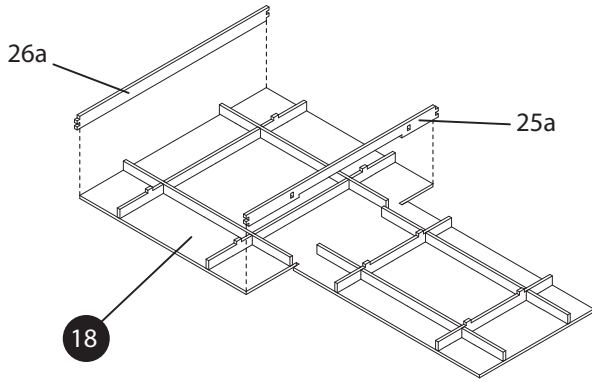

20

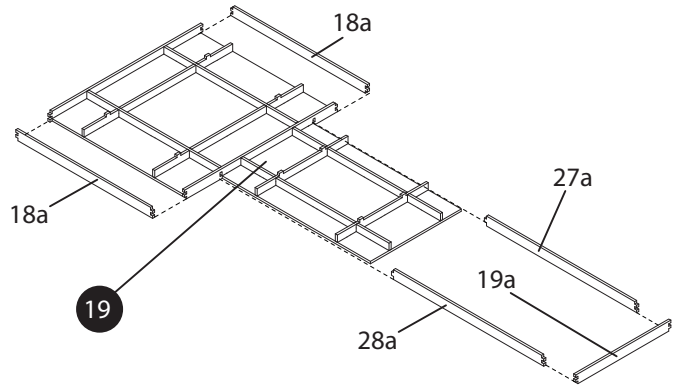

21

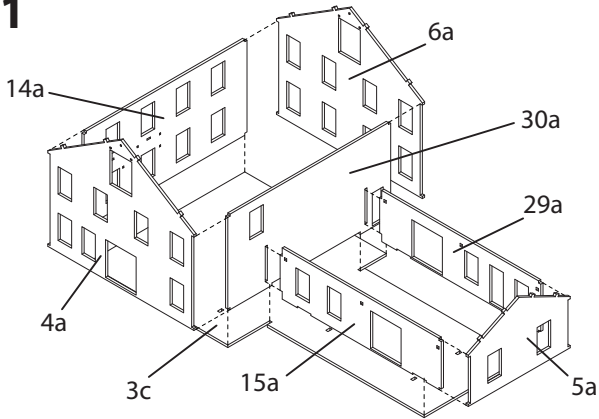

22

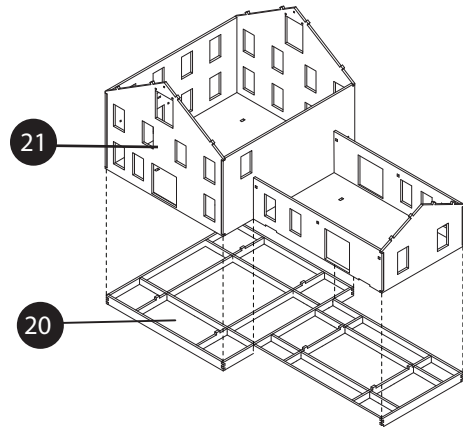

23

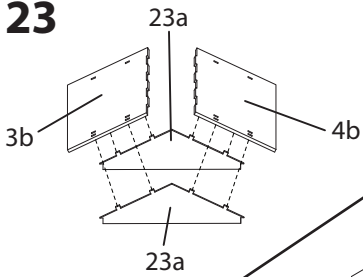

24

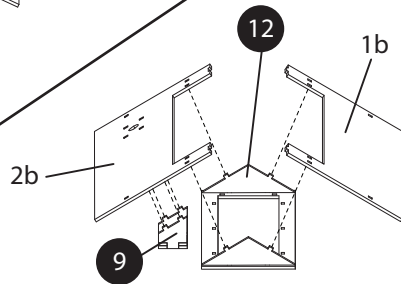

25

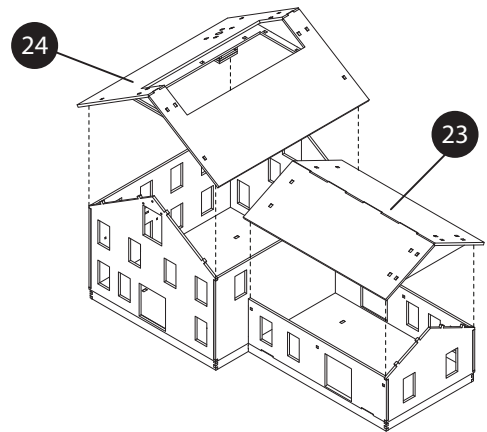

26

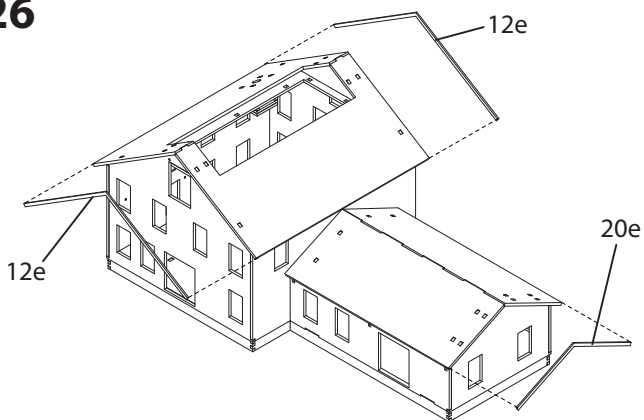

27

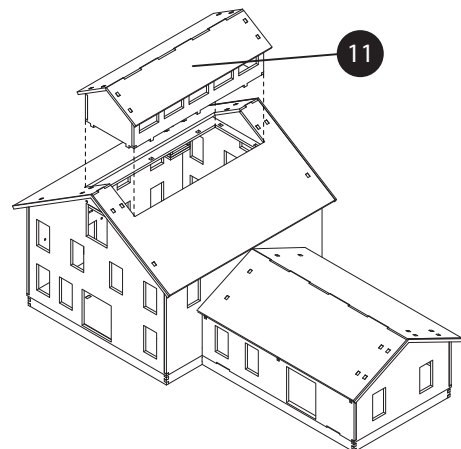

28

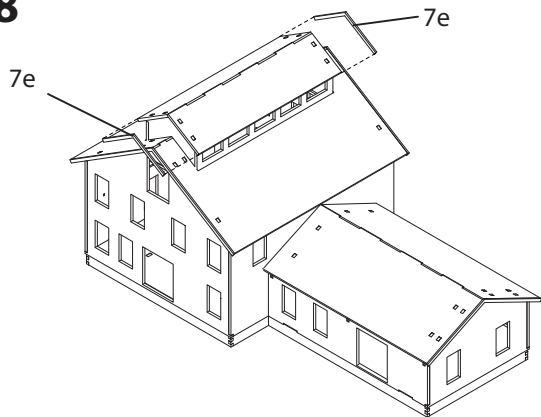

29

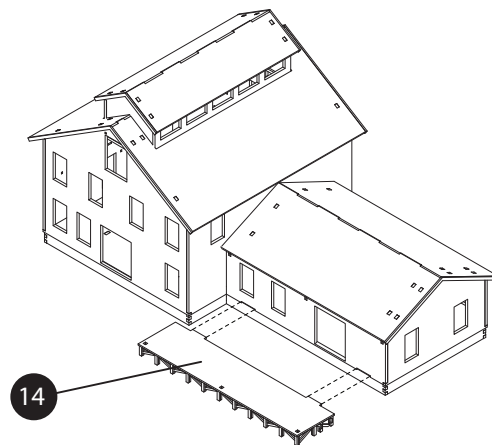

30

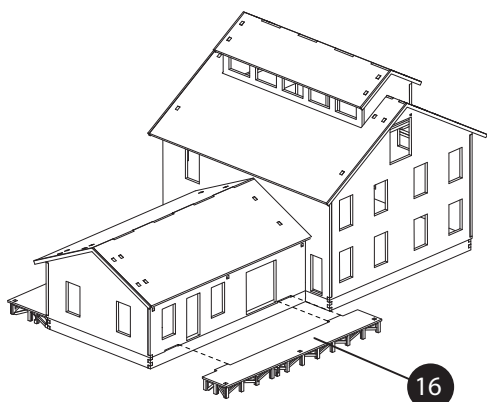

31

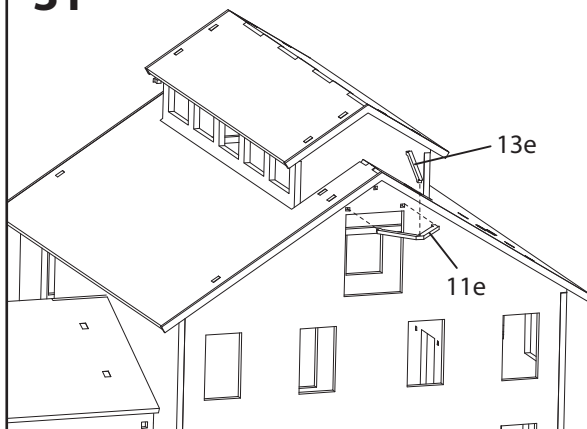

32

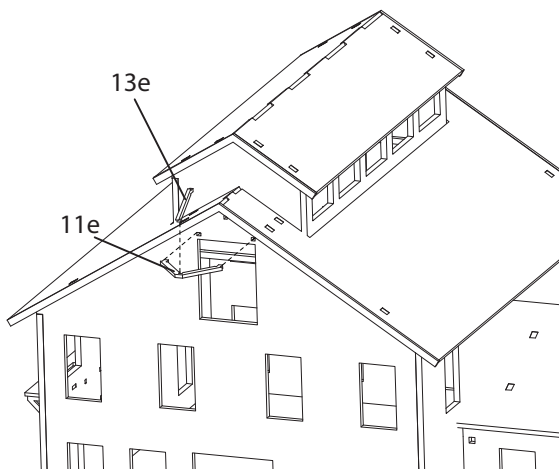

33

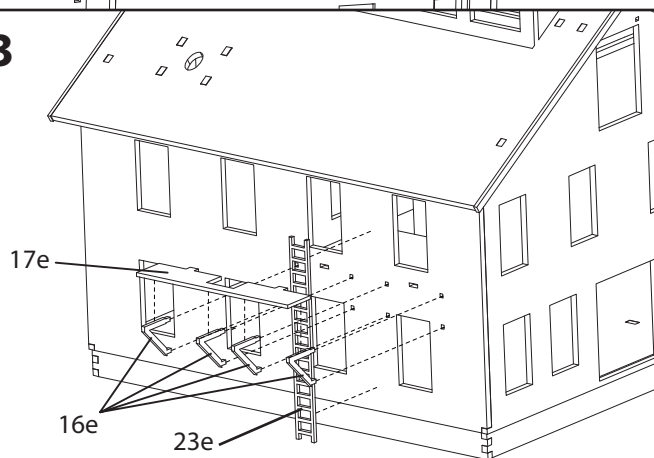

34

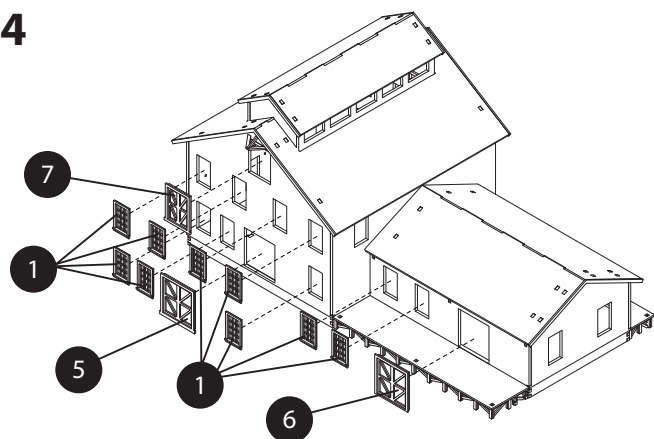

35

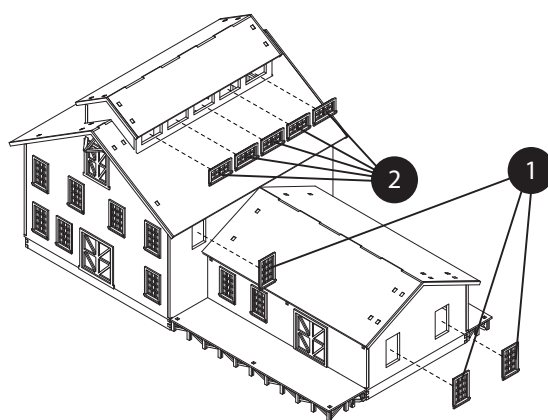

36

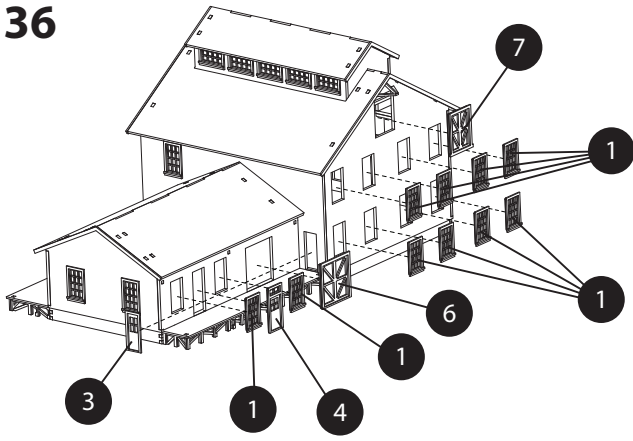

37

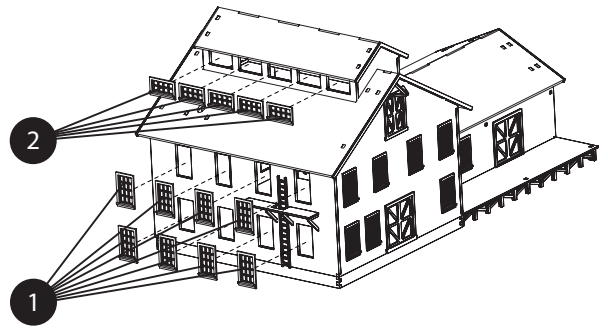

38

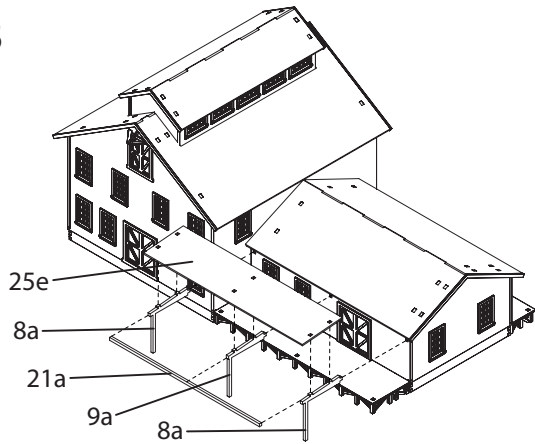

39

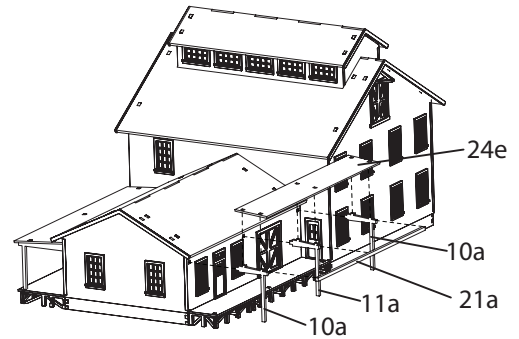

40

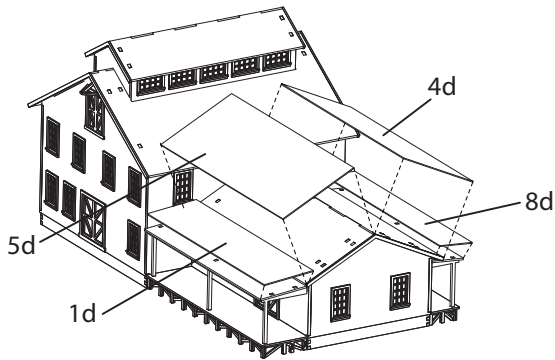

41

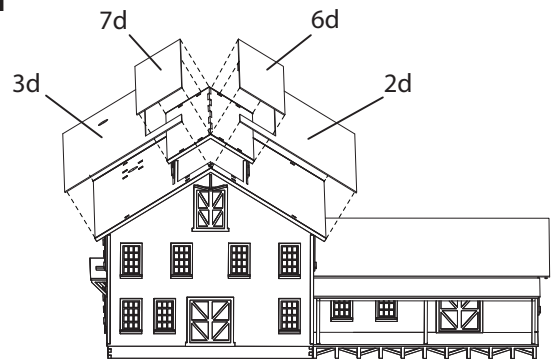

42

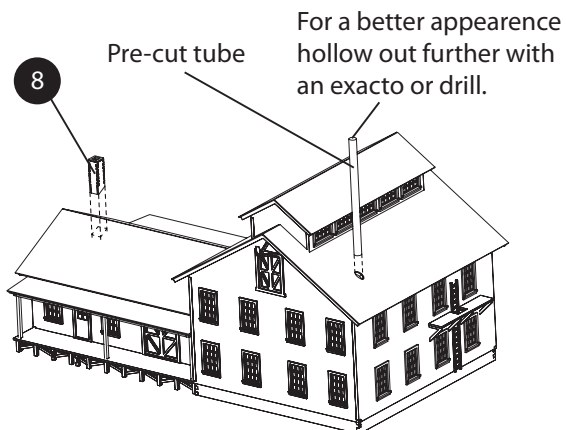

43

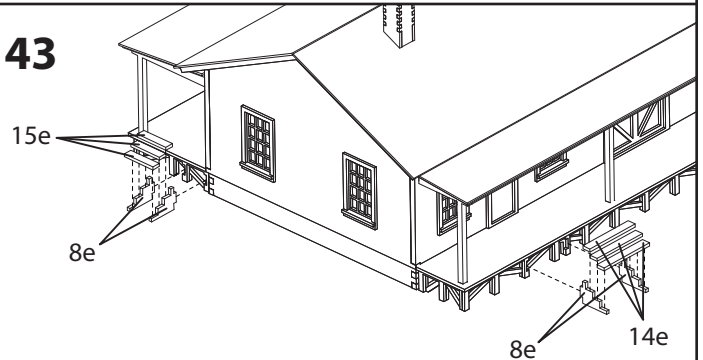

DECALS

See pictures below for decal placement. This kit is supplied with waterslide decals. To apply the decals cut them into separate sections and dip them into water for a few seconds. Remove the decal from the water and place on a moistened paper towel. After the decal releases from the backing paper slide the decal onto the model. Waterslide decals work best over a glossy surface. One good source of gloss coat is Future floor wax, just brush straight from the bottle or thinned with a little water and sprayed through an airbrush. My best results for wood models have been achieved by using a setting solution (I use Microscale Micro Sol). After the decal is on the model and positioned correctly brush on the Micro Sol. This solution actually softens the decal so it conforms to the surface of the model. I usually brush on a few coats, letting the decals dry between applications. If there are still some bubbles or "silvering" you can poke the "silvered" areas with the tip of a new exacto knife blade and then apply more setting solution. Repeat until all of the silvering or bubbles are gone. To seal everything use a flat overcoat (it's best to leave the clear parts off until this is done).

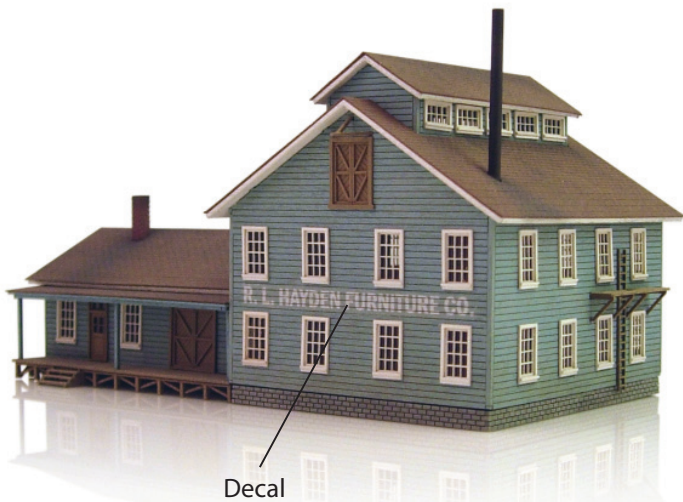

Decal

FRONT



Decal

BACK